

P12BMR

MOTORIZED HYDRAULIC PRESS
AUTOMATIC DOUBLE SPEED WITH FAST APPROACH
BENCH FRAME VERSION
CAPACITY 12 TONS

The P12BMR hydraulic press guarantees high performance and maximum executive precision. The monolithic frame is entirely laser cut and there are no frontal weldings. This feature makes all our presses non-deformable even at the points of greatest stress.

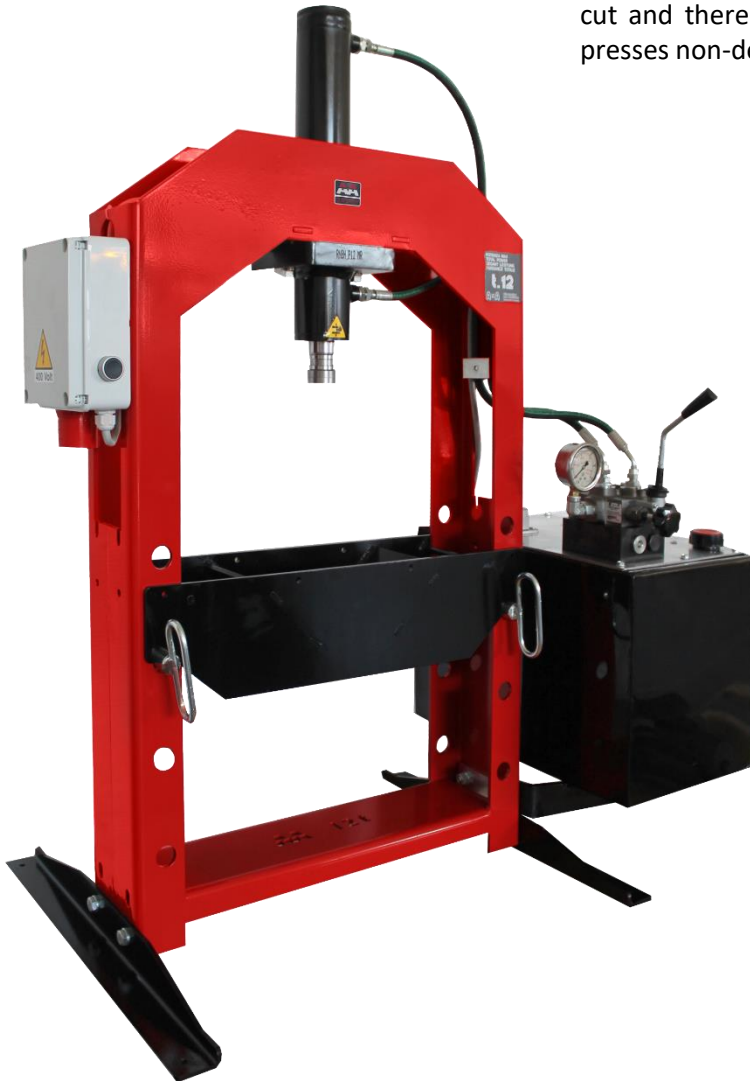

	UM	P12BMR
Max capacity	TON	12
Approaching speed (fast mode)	mm/min	1650
Approaching speed (slow mode)	mm/min	520
Cylinder stroke	mm	300
Stem diameter	mm	40
Shank diameter	mm	M14
Tank capacity	litri	30
Max pressure	bar	350
Tension	V	400
Frequency	Hz	50-60
Motor power	kW	1,5
Max power adsorption	A	2,8
Weight	Kg	150

*axaTOP:
Made in AxA*

A complete range of hydraulic presses from 12 to 110 tons always available in stock for prompt shipments.

BESPOKE presses to customer specifications and for special applications. Custom presses in terms of dimensions (height, width, depth), control panel and accessories.

All components are Made in Italy

- Hydraulic unit with ICME 400V and 50-60Hz immersed motor, cylinders and frames manufactured in AxA Group.
- GALTECH monobloc distributor.
- Nos. 2 unidirectional pumps in aluminum with external gears by VIVOIL. One for rapid approach and return (set at 20bar) and one with adjustable pressure with handwheel to set the required power.
- Relief valve with mechanical lock to prevent overpressure
- Block 2MP CETOP high range.
- Standard pressure gauge to display the power supplied.
- INTECH electrical panel certified according to current regulations and with autonomous CE marking.

AXATOP is a brand of AxA Group srl

Via Morandi 21, 40060 Toscanella di Dozza (Bologna) Italy Tel +39 0542673434

email: info@axatop.com website: www.axatop.com

P12BMR

MOTORIZED HYDRAULIC PRESS
AUTOMATIC DOUBLE SPEED WITH FAST APPROACH
BENCH FRAME VERSION
CAPACITY 12 TONS

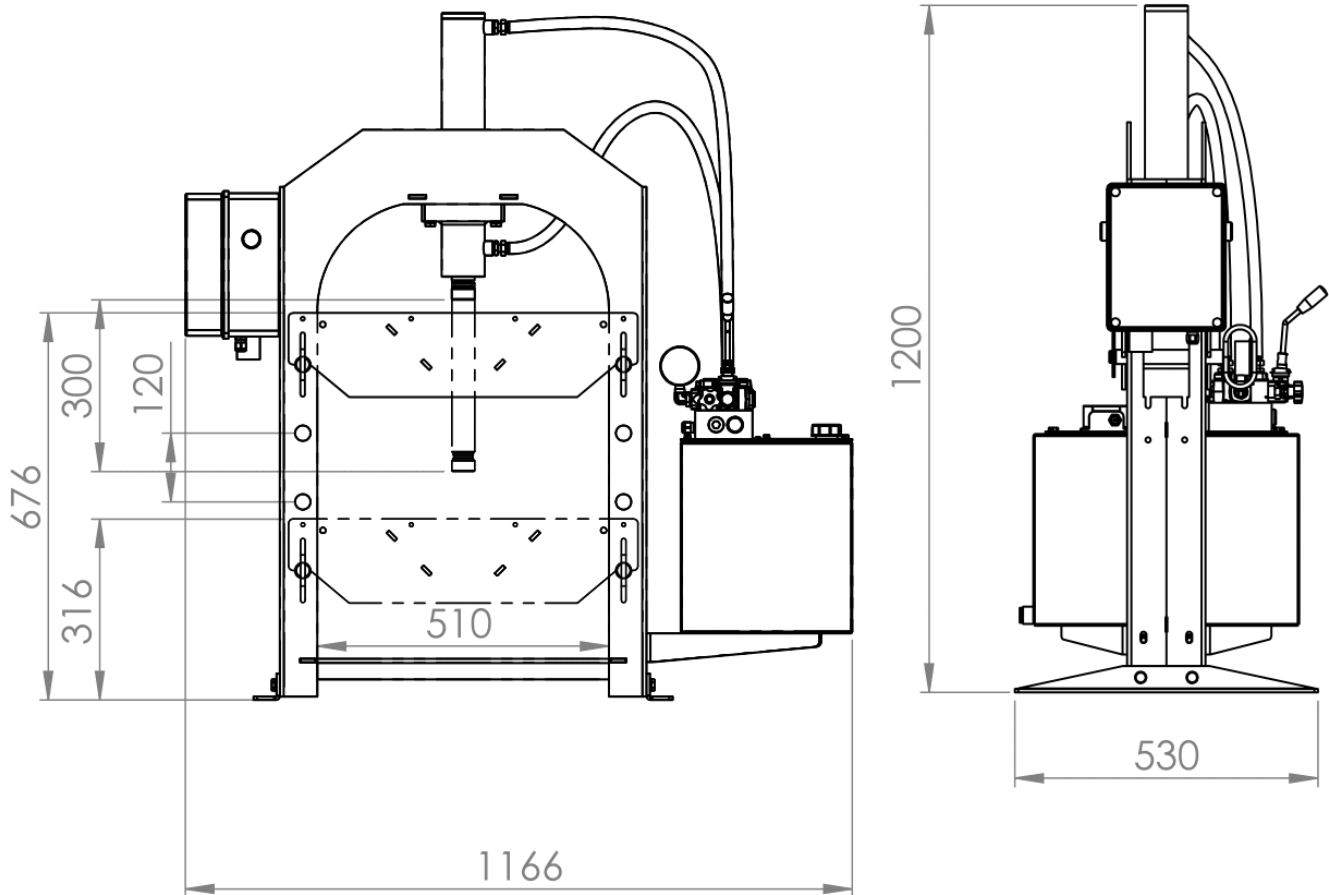

AXA Group produces a complete range of **OPTIONALS** and **ACCESSORIES**:

- plates, V-prisms, milled and T-slot worktops
- front and rear perimeter guards
- up and down limit switch microswitch
- **RAPID/SLOW** control system for operating the press with one hand within the limits set by current legislation
- switchboards for automatic presses with PLC
- increased cylinder rod strokes

All our presses are always accompanied by a user and maintenance manual, CE marking and a certificate of conformity in accordance with the current machinery directive and workplace safety directives.

Our hydraulic presses are made with the highest construction quality and guarantee unlimited reliability.

AXATOP is a brand of AxA Group srl

Via Morandi 21, 40060 Toscanella di Dozza (Bologna) Italy Tel +39 0542673434

email: info@axatop.com website: www.axatop.com